

NPN

New Product News



VT-CLAMP V TURN

Multifunctional V-Type Insert (TDMV)

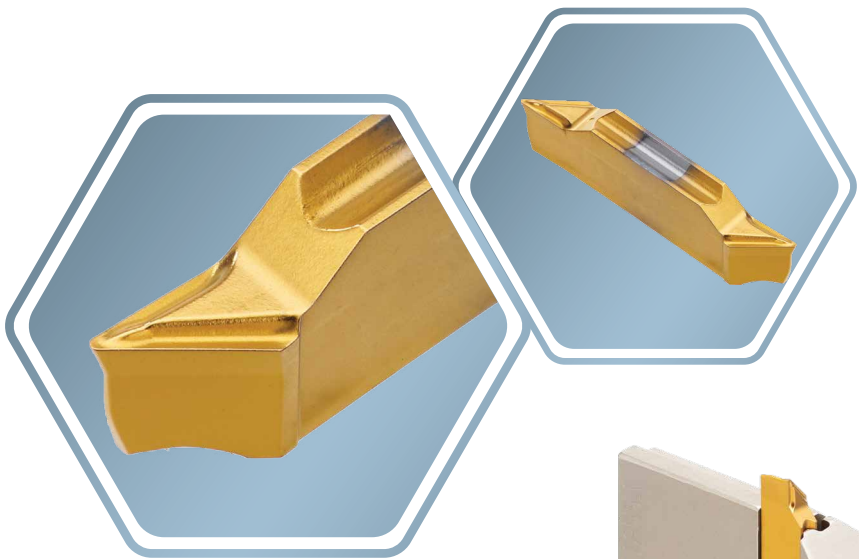

KEY POINT

TaeguTec introduces the V-type T-CLAMP insert that maximizes productivity by minimizing tool change through multifunctional machining.

In addition to operating on narrow grooving on typical CNC lathes, the new V-shaped TDMV inserts are suitable with a wide range of applications on Swiss automatic lathes, with a concentration on miniature product machining. The V-shaped TDMV insert line is a multipurpose option and the optimal tool for innovation in the groove machining segment in order to meet various customers' needs.

Features

- Versatile chip breaker: forward/backward turning, profiling, end facing and parting
- Optimized chip breaker design for bi-directional turning enables superior chip control
- Insert's 2.8 mm edge width allows for a variety of tasks in tight spaces
- Roughing and finishing capable with a cutting depth of up to 2.5 mm
- Available in 4 insert types: R/L-handed, Corner R0.2, R0.4
- Multi-application machining reduces tool cost and equipment downtime while maximizing productivity gains
- Compatible with standard holders, maximizing performance when using internal high-pressure feed-type holders

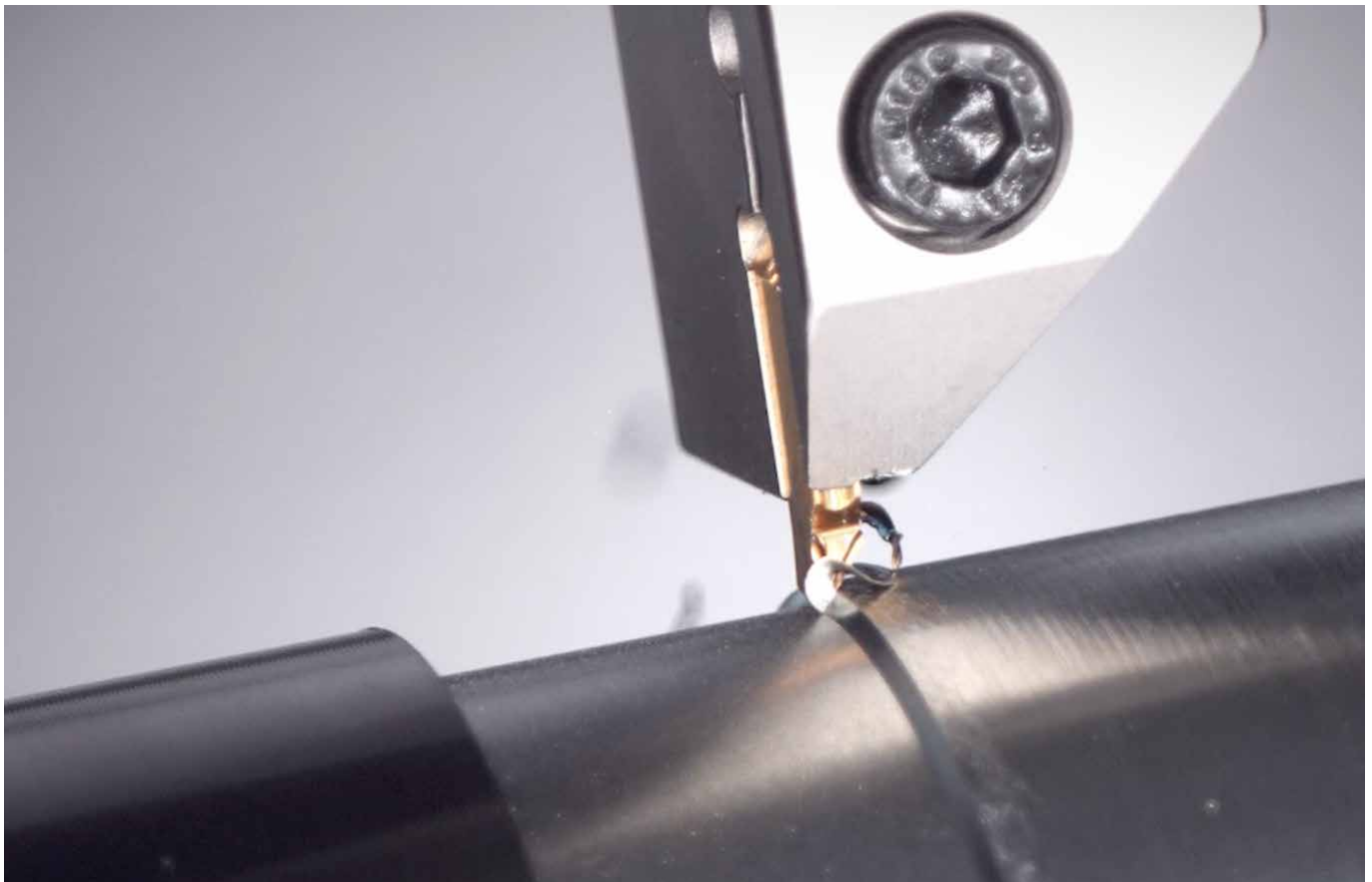

Features

- V-shape geometry and optimized chip breaker for excellent chip control in bi-directional turning

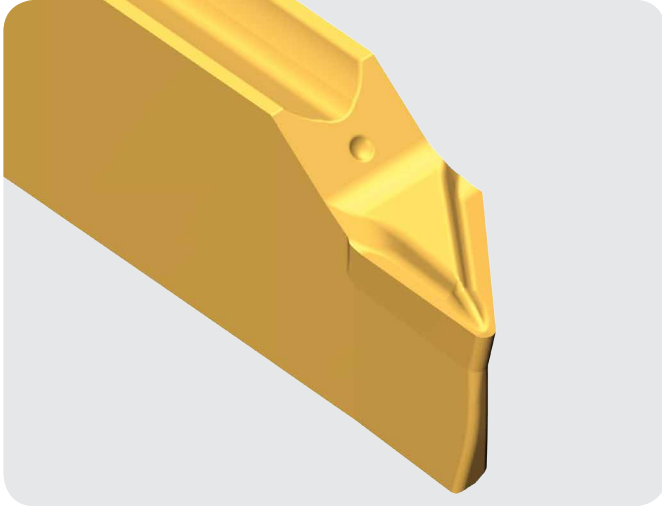

- 2.8 mm width of cut inserts for interference-free machining in confined areas when compared to conventional ISO V-type inserts

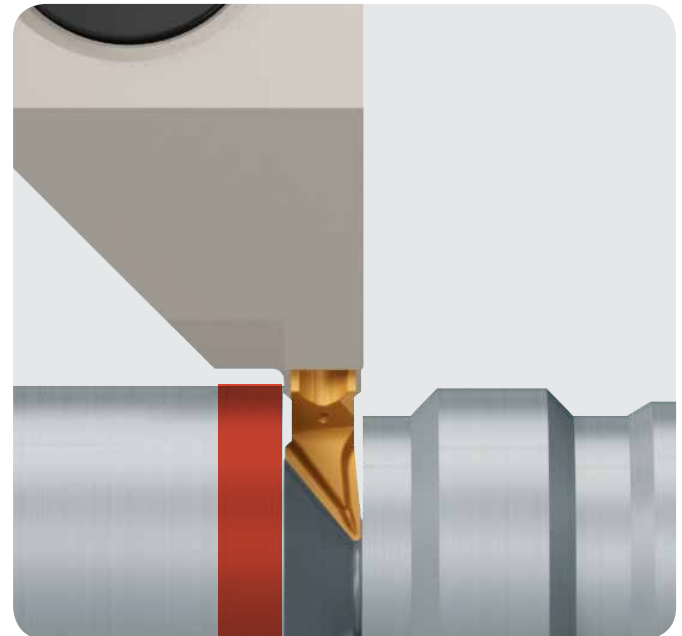
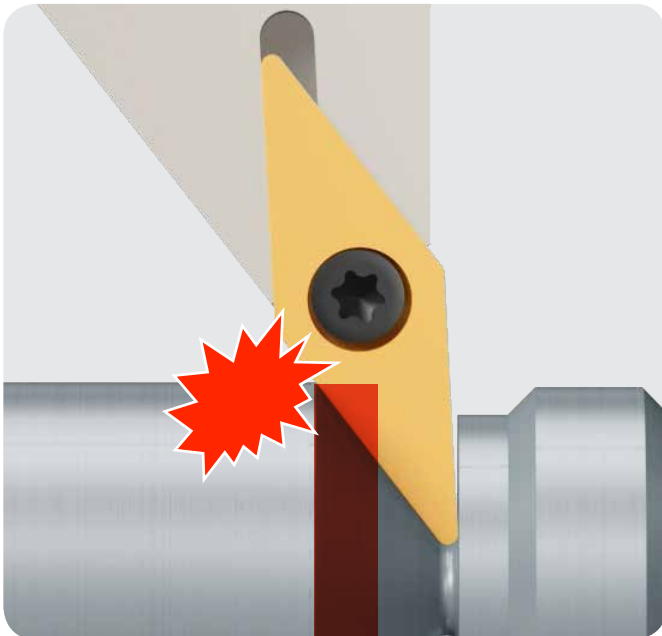

Various applications

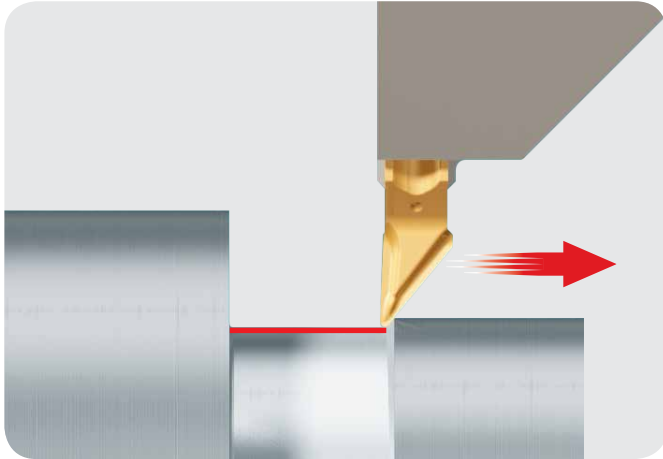

Backward turning

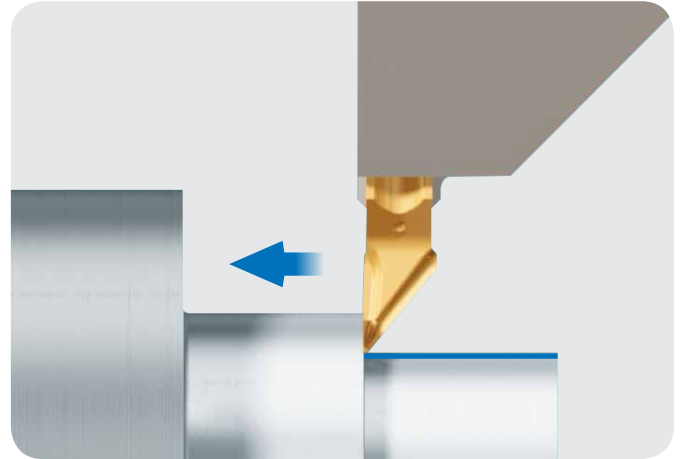

Forward turning

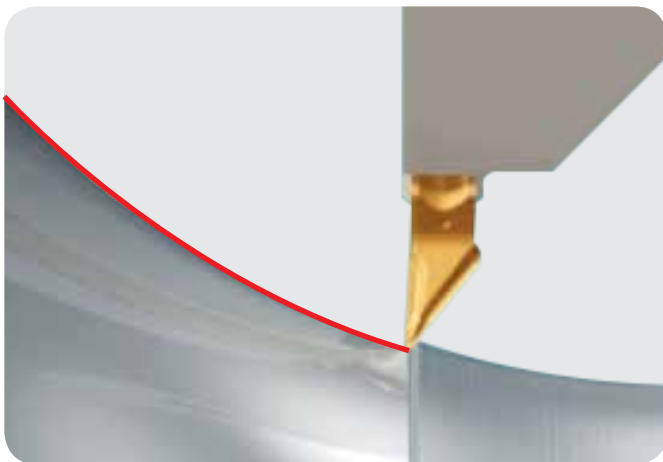

Profiling



Undercut



Face grooving

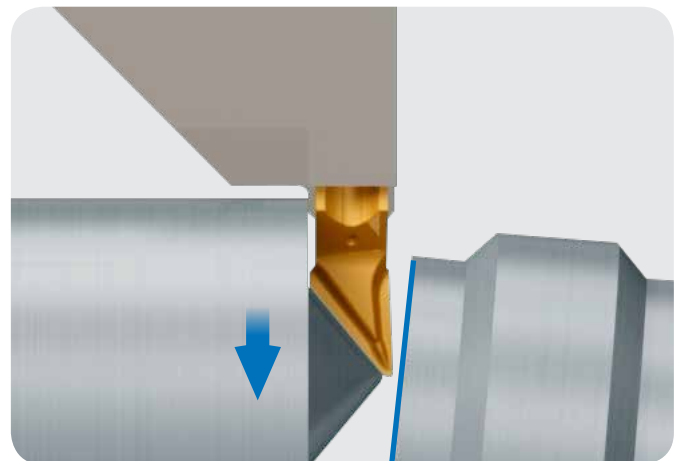

Parting

Recommended application range

TDMV 2.8E-0.2-R/L

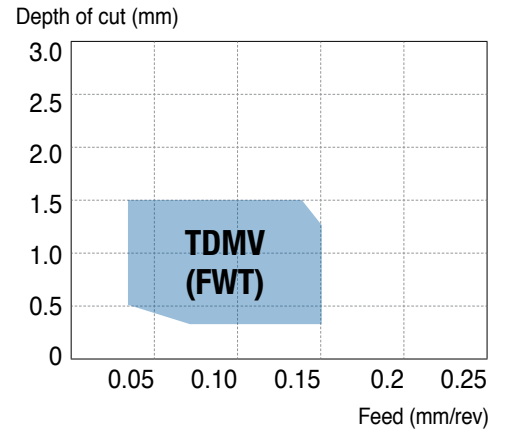
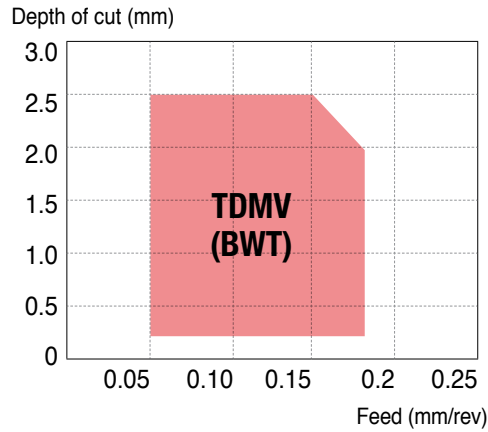
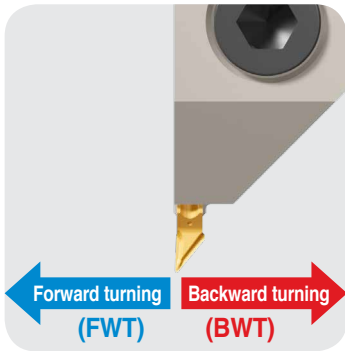

TDMV 2.8E-0.4-R/L

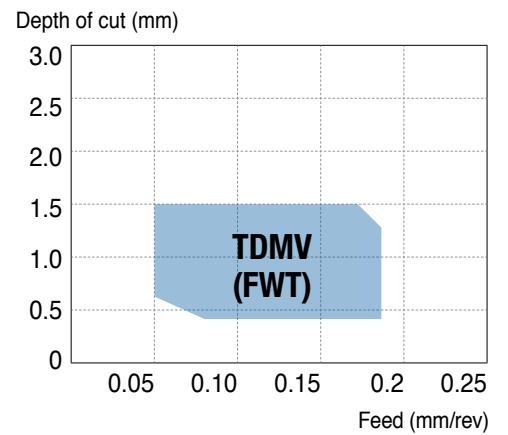
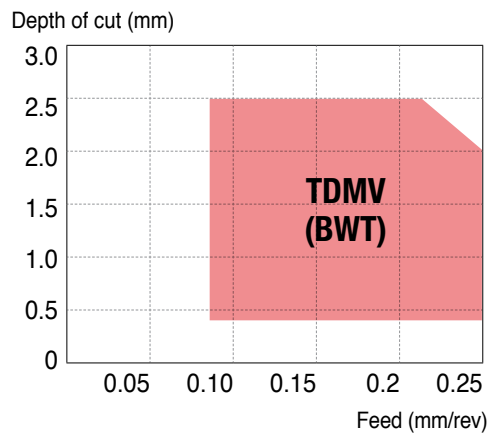
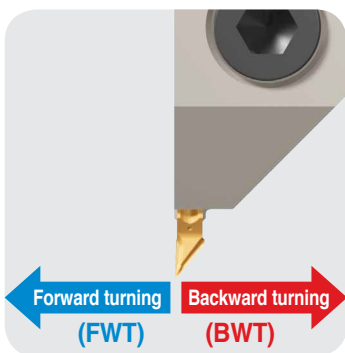

Recommended Cutting Conditions

Grooving and Turning

ISO	Material	Condition	Tensile strength (N/mm ²)	Hardness HB	Material No.	Cutting speed Vc (m/min)	
						TT9080	
P	Non-alloy steel, cast steel, free cutting steel	<0.25%C	Annealed	420	125	1	100-200
		>=0.25%C	Annealed	650	190	2	100-180
		<0.55%C	Quenched and tempered	850	250	3	80-160
		>=0.55%C	Annealed	750	220	4	80-160
			Quenched and tempered	1000	300	5	70-130
	Low alloy steel and cast steel (less than 5% of alloying elements)	Annealed	600	200	6	100-160	
		Quenched and tempered	930	275	7	80-160	
			1000	300	8	80-150	
			1200	350	9	80-130	
	High alloy steel, cast steel and tool steel	Annealed	680	200	10	90-130	
Quenched and tempered		1100	325	11	50-80		
M	Stainless steel and cast steel	Ferritic / martensitic	680	200	12	80-170	
		Martensitic	820	240	13	80-150	
		Austenitic	600	180	14	80-170	
K	Gray cast iron (GG)	Ferritic		160	15	100-230	
		Pearlitic		250	16	90-180	
	Cast iron nodular (GGG)	Ferritic		180	17	150-250	
		Pearlitic		260	18	100-230	
	Malleable cast iron	Ferritic		130	19	90-180	
		Pearlitic		230	20	90-180	
N	Aluminum - wrought alloy	Not cureable		60	21		
		Cured		100	22		
	Aluminum-cast, alloyed	<=12% Si	Not cureable		75	23	
			Cured		90	24	
	Copper alloys	>12% Si	High temp.		130	25	
		>1% Pb	Free cutting		110	26	
	Non-metallic	Brass			90	27	
		Electrolitic copper			100	28	
S	High temp. alloys	Fe based	Annealed		200	31	30-50
			Cured		280	32	20-40
		Ni or Co based	Annealed		250	33	20-30
			Cured		350	34	15-20
			Cast		320	35	15-20
	Titanium, Ti alloys		Rm 400		36	130-170	
		Alpha+beta alloys cured	Rm 1050		37	40-70	
H	Hardened steel	Hardened		55HRC	38		
		Hardened		60HRC	39		
	Chilled cast iron	Cast		400	40		
	Cast iron nodular	Hardened		55HRC	41		

■ Steel
 ■ Stainless steel
 ■ Cast iron
 ■ Nonferrous
 ■ High temp. alloys
 ■ Hardened steel